

1、Product Description

- Built-in High-performance, Low-power Microcontroller
- Efficient cooling solution such small size, light weight
- One relay output
 - 3A AC250V
 - 3A DC30V
- Peripheral Features
 - Support 4-20mA and 0-5/10V (potentiometer) two given
 - Two switch inputs
 - Wide Range Of Primary Loop Voltages (AC110-440V)
- Practical alarm function
 - Phase failure
 - Overheat
 - Overcurrent
 - Load break
- To facilitate centralized control RS485 communication

2、Size

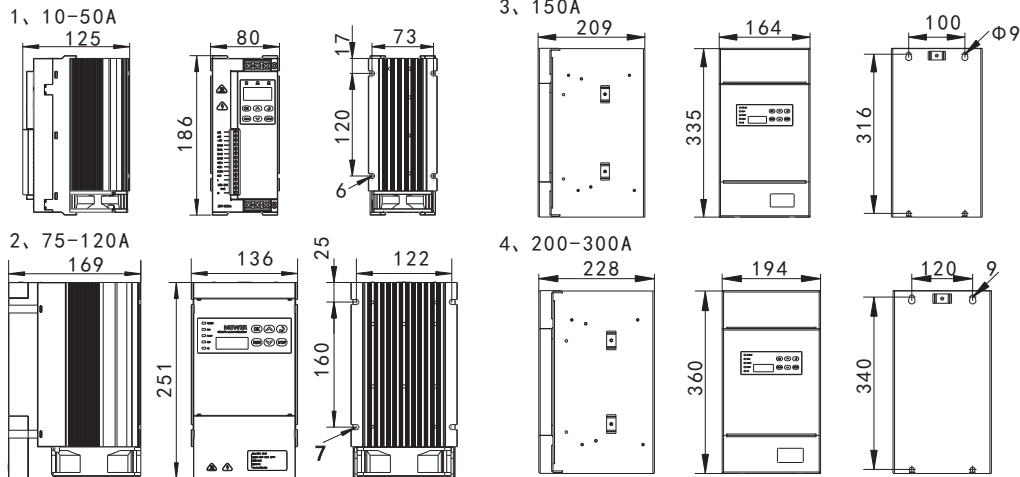

3、Keyboard operation

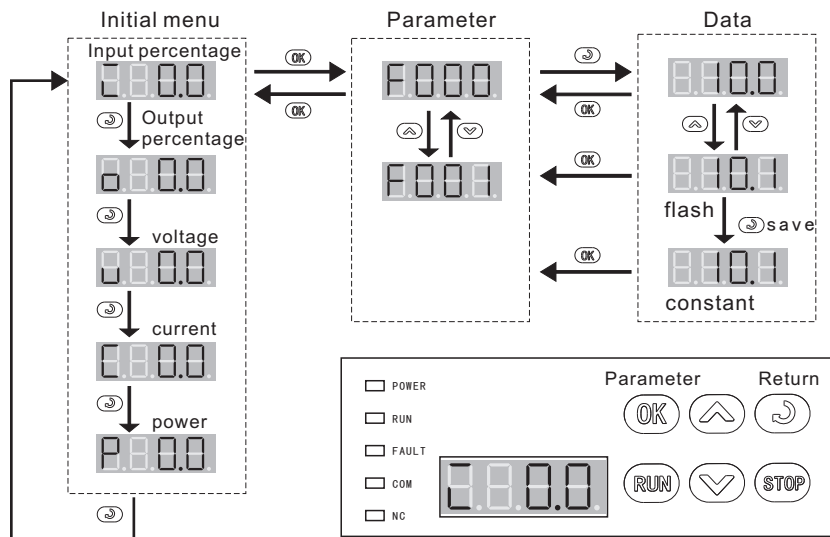

4、Terminal description

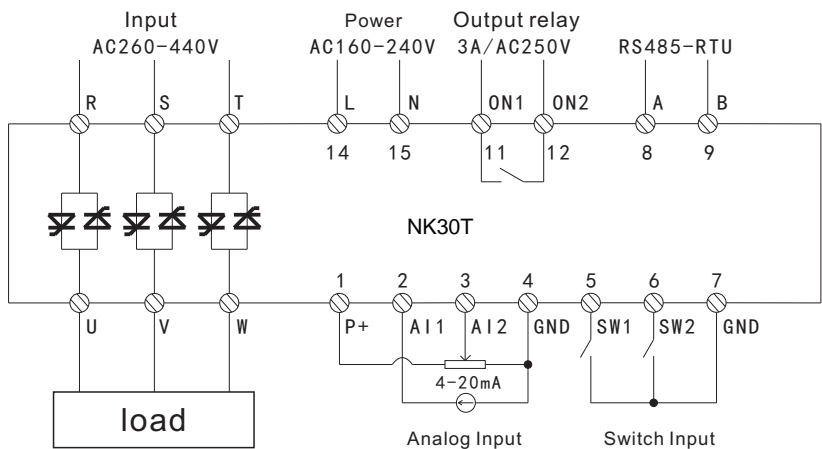

The default is stop start signal SW1, SW2 default switch between A1 and A2, closed A2 given signal is valid, disconnect A1 given signal is valid.

5、Communication

30T Series power regulator supports Modbus protocols. Modbus supports 3, 4, 6, 16, totally 4 functions, F-35: slave station address: 1-247, F-36 baud rate: 2400 4800 9600 19200 38400. F-37: data format: 8n2 8e1 8o1, 3 types. Parameter value is 16bits no signal register, decimal point is not supported. For example, before writing 56.7, it should be adjusted as 567 and then re-write.
Notice: every frame cannot exceed 20 bytes, so every frame can maximum read 10 parameters. The register of the host computer starts from 1 and the register number is incremented by 1. If the register number is F004, it should be filled with 5.

▶ Read Holding Registers frame format

0	1	2	3	4	5	6	7
Addr	Function 03H	Starting Address Hi	Starting Address Lo	No. of Points Hi	No. of Points Lo	CRC H	CRC L

▶ Preset Single Register frame format

0	1	2	3	4	5	6	7
Addr	Function 06H	Starting Address Hi	Starting Address Lo	Preset Data Hi	Preset Data Lo	CRC H	CRC L

6、Fault and maintenance

1、Fault list

fault code	description
E002	Main power fault, possible fault reason: 1. No voltage of mail loop or not the same of nameplate. 2. Synchronous cable of terminal 12 is not connected, please refer to the wiring drawing.
E003	Overcurrent, measured current exceeds 1.25 time of rated current, possible reason: 1. Load changes rapidly or short-circuit. 2. Thyristor breaks.
E004	Load-off, load off current = set-point percentage * rated current * load threshold, alarms when difference between set-pint and measured current is bigger than load off current. Possible reason: 1. Load off 2. Load current is small 3. Setting of(F-45)is small
E005	Overheat of regulator, heat-sink temperature is bigger than 85, possible reason: 1. Ambient temperature is higher than 45. 2. Fan breaks. 3. Dust on the ventilation path.

7、basic parameter

Above chapter is the brief operation parameter, R: readable parameter, RW: readable and writeable parameter. Please change parameter when regulator stops.

parameter no.	description	range	default	Attributes	
F-000	Valid output	0-100.0 [%] 0.1%	-	R	0
F-001	Valid input	0-100.0 [%] 0.1%	-	R	1
F-002	Output voltage	0-3000.0 [V] 0.1V	-	R	2
F-004	A phase Output current	0-3000.0 [A] 0.1A	-	R	4
F-005	B phase Output current	0-3000.0 [A] 0.1A	-	R	5
F-006	C phase Output current	0-3000.0 [A] 0.1A	-	R	6
F-007	Output power	0-3000.0 [KW] 0.1KW	-	R	7
F-008	Start/stop signal Signal source of start/stop 0: switch off 1: switch on	0-1 1	0	R	8
F-009	Digital setting signal input	0-100.0 [%] 0.1%	0	RW	9
F-010	Start-stop control mode selection 0: External switch 1: panel	0-1 1	0	RW	10
F-011	Given signal type selection 0: Analog 1: Digital	0-1 1	0	RW	11
F-012	Current analog type 0: 0-20mA1: 4-20mA 2: Integrated slope control	0-2 1	1	RW	12
F-013	Ramp-up time Signal processing before the ramp from 0.0% to 100% of the time required	0-120 1	2	RW	13
F-014	Ramp-down time Before the ramp signal processing dropped from 0.0% to 100% of the time required	0-120 1	2	RW	14
F-015	Output ceiling Maximum output limit	0-100.0 [%] 0.1%	100.0	RW	15
F-016	Output limit Output minimum value	0-100.0 [%] 0.1%	0	RW	16
F-017	Proportion PID control proportional factor	0-200 1	80	RW	17
F-018	Integral PID control integral time	0-200 1	5	RW	18
F-019	Differential PID control differential time	0-200 1	0	RW	19
F-020	Feedback signal source 0: Voltage 1: current 2: power	0-2 1	0	RW	20
F-021	Limiter signal source 0: Current 1: Voltage	0-1 1	0	RW	21
F-022	Limit percent Set as a percentage of the limit signal	0-100.0 [%] 0.1%	100	RW	22
F-023	Control mode 0: Closed-loop phase shift 1: Open loop phase shift 2: Zero trigger	0-2 1	0	RW	23
F-027	A1 end correction This parameter is set so that 20mA corresponds to a given input 100%	50-150.0 [%] 0.1%	100.0	RW	27
F-029	A2 end correction This parameter is set so that 5V/10V corresponds to a given input 100%	50-150.0 [%] 0.1%	100.0	RW	29
F-029	A1 Signal selection 0: 0-5V 1: 0-10V	0-1 1	0	RW	33
F-035	Device Address This parameter sets the Modbus address	0-247 1	123	RW	35
F-036	Baud Rate 0: 2400 1: 4800 2: 9600 3: 19200 4: 38400	0-4 1	2	RW	36
F-037	Data format 0: 8n2 Date bit 8 bits, no calibration, 2 stop bits 1: 8e1 Date bit 8 bits, parity - checking, 1 stop bits 2: 8o1 Date bit 8 bits, odd parity -checking, 1stop bits	0-2 1	1	RW	37
F-040	Output relay 0: Fault 1: Start status	0-1 1	0	RW	40
F-041	Previous fault	0-100 1	-	RW	41
F-042	Allow overcurrent protection 0: Disable 1: Enable	0-1 1	1	RW	-
F-043	Phase protection permit 0: Disable 1: Enable	0-1 1	1	RW	-
F-044	Load fault protection enables 0: Disable 1: Enable	0-1 1	1	RW	-
F-045	Load-off threshold	10-70 [%] 1%	70	RW	-
F-046	Thyristor thermal protection allows 0: Disable 1: Enable	0-1 1	1	RW	-
F-048	Rated voltage: The same as nameplate. Data can be changed according to actual load, for the purpose of protecting device Notice: cannot exceed nominated value on the nameplate	0-3000 [V] 0.1V	380	RW	48
F-049	Rated current: The same as nameplate. Data can be changed according to actual load, for the purpose of protecting device Notice: cannot exceed nominated value on the nameplate	0-3000 [A] 0.1A	-	RW	49
F-050	Frequency 0: 50HZ 1: 60HZ 2: Automatic tracking	0-2 1	0	RW	50